

More with SKF Explorer deep groove ball bearings



**SKF Explorer™ deep groove ball bearings
with RSL and RSH seals**

- Improved precision and silent running
- Enhanced sealing properties
- Low friction
- Extended service life



A new generation of seals offers more possibilities

The most popular bearing

The deep groove ball bearing is the most widely used bearing type on the market. The versatile design makes it the preferred solution for applications that operate under combined radial and axial loads at high speed.

SKF offers a wide range of deep groove ball bearings in open, shielded and sealed designs. The shielded and sealed designs offer many advantages over an open design, making it a preferred choice in many applications.

When sealed on both sides, the bearings are greased for life and require virtually no maintenance. They are also easy to mount.

SKF has developed two new seals that provide extended service life. These two sealing alternatives are the SKF standard for sealed deep groove ball bearings in the range specified in this brochure.

This publication provides information about the two new SKF seals:

- The RSL low-friction seal that replaces the RZ low-friction seal.
- The RSH contact seal that replaces the RS1 contact seal.

This publication provides also general information about SKF Explorer deep groove ball bearings.

The range

The current range of deep groove ball bearings with seals of the new generation covers bearings

- in the 60, 62 and 63 series
- with a bore diameter ranging from 6 to 25 mm
- with a 52 mm maximum outside diameter.

The bearings can be sealed on both sides, or on one side only.

A wide range of applications

Industrial segments worldwide specify SKF sealed deep groove ball bearings. Some of the major applications include

- agriculture and forestry equipment
- automotive and industrial gearboxes
- automotive and truck electric components, such as alternators
- electric motors
- fluid machinery
- material handling
- power tools and household appliances
- textile machinery
- two wheelers.

Deep groove ball bearings with the new RSL and RSH seals respectively

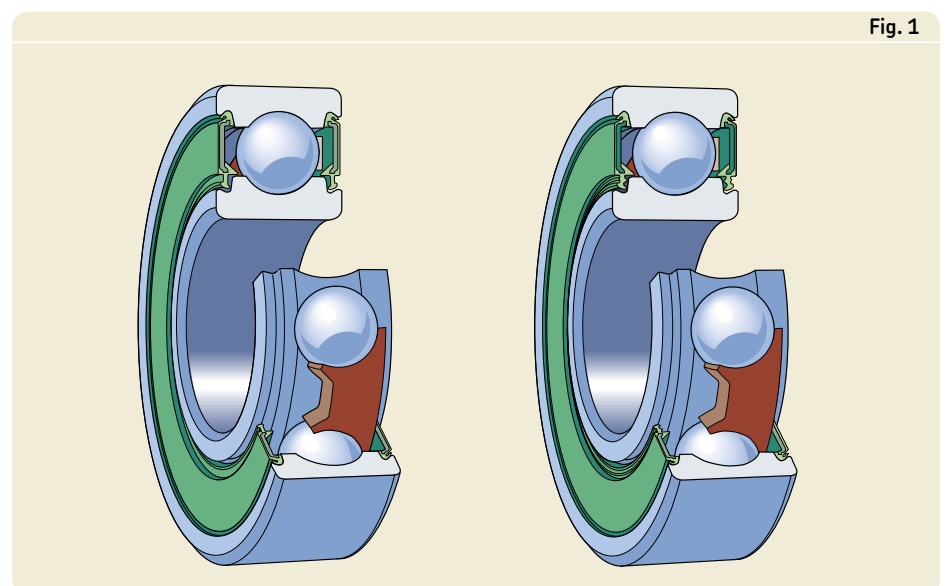

Data – general

Data related to general dimensions, tolerances, and internal clearance of bearings with the new RSL or RSH seals remain unchanged compared to bearings previously equipped with RZ or RS1 seals.

Detailed information is provided in the SKF General Catalogue.

Common properties of the seal designs

RSL and RSH seals share many important properties including the elastomer material and reinforcement.

Seals

The RSL and RSH seals are made of acrylonitrile-butadiene rubber (NBR), which has an operating temperature range of -40 to $+100$ °C and up to $+120$ °C for brief periods. The seals provide good resistance to

- most mineral oil based lubricants
- fuels, including petrol, diesel and light heating oils
- oils and greases based on animal and vegetable fat
- water.

A robust design and adequate contact force have been achieved by optimizing the shape of the seal lip using FEM calculations.

Sealing efficiency is provided by a combination of the seal lip and an additional labyrinth

formed by a gap between the tapered rubber part and the inner ring shoulder.

Reinforcement

Use of a uniquely shaped sheet steel reinforces the rubber material, making the seal stiff while keeping the body lean. There is more axial space available inside the bearing improving lubrication conditions and providing extended service life. The seal retainment in the outer ring has been optimized, providing proper sealing function in outer ring rotating applications.

Seal counterface

To provide extended bearing service life, lip wear is reduced by manufacturing the seal counterfaces to very high precision and providing recesses in the inner ring shoulders for the seal lip to slide.

The RSL low-friction seal

Depending on bearing size and available space, there are two different designs. The seal for bearings with

- an outside diameter smaller than 25 mm is shown in **fig. 2**
- an outside diameter larger than 25 mm is shown in **fig. 3**.

Compared to the RZ low-friction seal for the same operating conditions (→ **table 1**), the RSL low-friction seal provides

- improved grease retention
- improved exclusion of moisture and contaminants.

Bearings with the RSL low-friction seal can be identified by the designation suffix

- RSL: a seal on one side of the bearing, e.g. 6203-RSL
- 2RSL: a seal on both sides of the bearing, e.g. 6204-2RSL.

The RSH contact seal

In addition to the mentioned properties of the RSL low-friction seal, the SKF contact seal incorporates the following features:

- A secondary seal lip withstands high pressure cleaning and prevents water entry. The contact pressure between this seal lip and the seal counterface increases when pressure is applied to the outside of the bearing, while the lip design features prevent the seal from being pressed into the bearing.
- Seals for bearings with an outside diameter larger than 25 mm, have radial slots in the tapered attachment. These provide the contact area between seal lip and counterface with proper lubrication, enabling the grease to act as a third protection. This also contributes to extended bearing service life.

There are also two RSH designs. They differ slightly in the position of the primary seal lip, depending on bearing size and available space. The seal for bearings with

RSL seal design for an outside diameter smaller than 25 mm

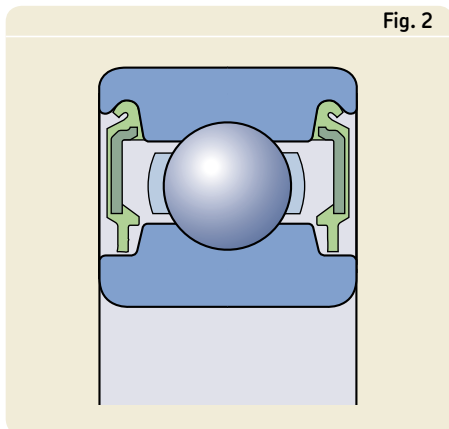

Fig. 2

RSL seal design for an outside diameter larger than 25 mm

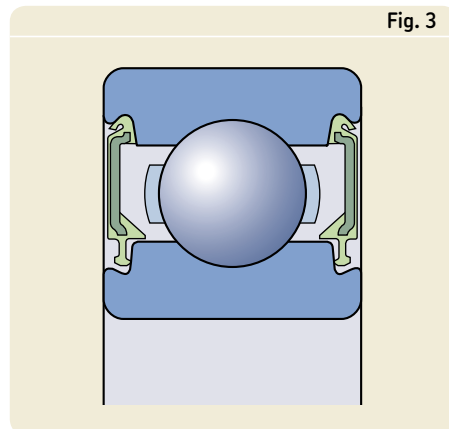

Fig. 3

Performance comparison between RSL and RZ seals

Characteristics	Seal type	
	RSL	RZ
Low friction	++	+++
Speed ability	+++	+++
Grease retention	+++	+
Dust exclusion	++	+
Static water exclusion	0	–
Dynamic water exclusion	0	–
High pressure water exclusion	0	–

Symbols:
 +++ = excellent ++ = very good + = good 0 = fair
 – = not recommended

Fig. 4

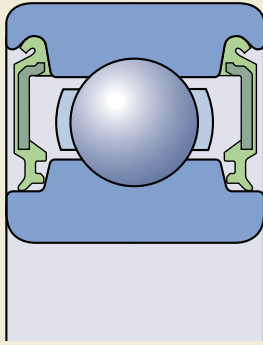

RSH seal design for an outside diameter smaller than 25 mm

- an outside diameter smaller than 25 mm is shown in **fig. 4**
- an outside diameter larger than 25 mm is shown in **fig. 5**.

Compared to the RS1 contact seal for the same operating conditions (→ **table 2**), the RSH contact seal provides

- increased grease retention
- improved exclusion of contaminants and water, specifically under high-pressure water impact.

Bearings with the RSH contact seal can be identified by the designation suffix

- RSH: a seal on one side of the bearing, e.g. 6203-RSH

Standard metal sheet cage

Fig. 6



Fig. 5

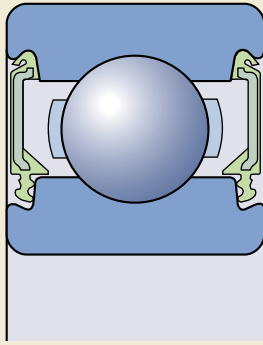

RSH seal design for an outside diameter larger than 25 mm

- 2RSH: a seal on both sides of the bearing, e.g. 6204-2RSH.

SKF Explorer deep groove ball bearings

SKF Explorer deep groove ball bearings benefit from many improvements, related to

- high precision
- silent running
- shields and seals
- material
- cages
- lubrication

to meet your application requirements.

Polyamide 6,6 cage

Fig. 7

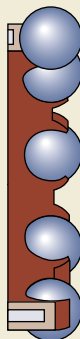

Table 2

Characteristics	Seal type	
	RSH	RS1
Low friction	o	o
Speed ability	o	o
Grease retention	+++	++
Dust exclusion	+++	+++
Static water exclusion	+++	++
Dynamic water exclusion	+	+
High pressure water exclusion	+++	o

Symbols:
+++ = excellent ++ = very good + = good o = fair

Performance comparison between RSH and RS1 seals

Precision and silent running

SKF Explorer deep groove ball bearings are produced to higher precision than the ISO Normal tolerances. The dimensional accuracy corresponds to P6 tolerances, except the width tolerance, which is considerably tighter and reduced to

- 0/-60 µm for bearings with an outside diameter up to 110 mm and
- 0/-100 µm for larger bearings.

Brass cage

Fig. 8

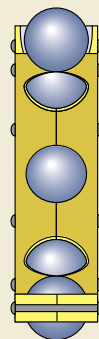
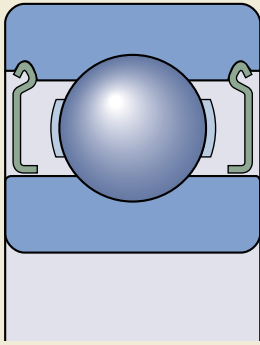

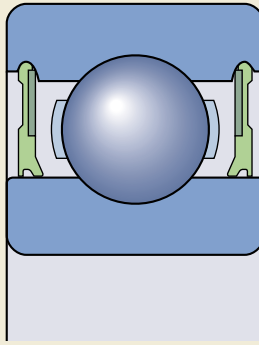

Fig. 9



Z shield design

Fig. 10



RZ seal design

Fig. 11

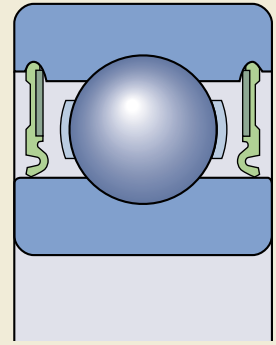

RS1 seal design

The running accuracy depends on the bearing size and corresponds to

- P5 tolerances for bearings up to 52 mm outside diameter
- P6 tolerances for bearings above 52 mm up to 110 mm outside diameter
- Normal tolerances for larger bearings.

Higher precision as well as lower noise and vibration levels result in quieter bearings with higher speed capabilities. This was achieved by continuous improvements in cleanliness, ring and ball quality, silent greases, etc., developed and implemented over a number of years.

Shields and seals

Depending on series and size, SKF Explorer deep groove ball bearings can be supplied with

- Z shields (→ fig. 9)
- RSL (→ fig. 2 and 3) or RZ low-friction seals (→ fig. 10)
- RSH (→ fig. 4 and 5) or RS1 contact seals (→ fig. 11).

An overview is provided in table 3.

Sealed SKF Explorer deep groove ball bearings and performance comparison

Table 3

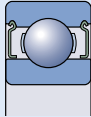
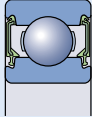
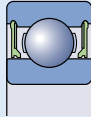
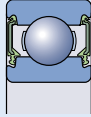
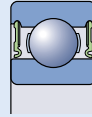
					
	Shield Z	Low-friction seal RSL	RZ	Contact seal RSH	RS1 ¹⁾
Applicable series ²⁾					
60	607 – 6026	607 – 6005	6006 – 6008	607 – 6005	6006 – 6026
62	625 – 6222	626 – 6205	6206, 6208	626 – 6205	6206 – 6221
63	635 – 6319	6300 – 6304	6305, 6306	6300 – 6304	6305 – 6319
Characteristics ³⁾					
Low friction	+++	++	+++	0	0
Speed ability	+++	+++	+++	0	0
Grease retention	0	+++	+	+++	++
Dust exclusion	0	++	+	+++	+++
Static water exclusion	–	0	–	+++	++
Dynamic water exclusion	–	0	–	+	+
High pressure water exclusion	–	0	–	+++	0

¹⁾ See SKF General Catalogue for more information on seal design.
²⁾ Availability to be checked with SKF or SKF distributors
³⁾ Symbols: +++ = excellent ++ = very good + = good 0 = fair – = not recommended

Material

SKF Explorer deep groove ball bearings are made from high quality carbon chromium steel for through hardening, to obtain high fatigue strength and wear-resistance.

Cages

Most SKF Explorer deep groove ball bearings are fitted as standard with a riveted, pressed steel cage (→ fig. 6).

For particular applications, bearings can be supplied with other cage types, such as

- glass fibre reinforced polyamide 6,6. (suffix TN9, → fig. 7). The unique material properties of TN9 cages provide numerous advantages, such as high-speed capability and lower sensitivity to poor lubrication. The trend is to use polyamide cages when continuous operating temperature is below 120 °C
- machined brass cages (→ fig. 8).

Lubrication

Bearings with a shield or a seal on both sides are greased for life. SKF has selected a range of proven greases, covering most applications (→ table 4).

To meet specific applications need, all bearings can be filled with tailored greases on request.

Advanced features and function integration

For demanding applications, SKF can supply deep groove ball bearings with specific features such as

- special steel
- ceramic balls
- high temperature resistant polymer cages (PA46, PEEK)
- seals from special rubber mixes (ACM, FKM)
- electrically insulated (INSOCOAT®)
- seize-resistant
- graphite segment cages for extreme temperature (kiln truck bearing)
- integrated oil seal (ICOS® bearing)
- Solid Oil
- integrated sensors.

An SKF deep groove ball bearing is always a vital component of a global mechanism. Its specific role as the heart of the system – supporting the shaft, carrying loads and inter-

facing fixed and rotating components – drives SKF to integrate more functions in the volume location of a standard deep groove ball bearing.

SKF "intelligent units" integrate additional robust functions. These "fit and forget" solutions contribute to a simplified mounting process and reduced number of parts. Typical examples are Sensor-Bearing Units.

SKF provides detailed mounting instructions, available on www.skf.com/mount.

In addition to bearings and seals, SKF offers the advantages of an international industrial group operating in some 130 countries with an

- international sales network including a large number of sales companies and some 15 000 distributors and retailers
- worldwide international standard quality certification to ISO 9001 and ISO/TS 16949/2002
- global ISO 14001 environmental certification and global health and safety management standard OHSAS 18001 certification.

Technical specifications of SKF greases for sealed deep groove ball bearings

Characteristics	Standard grease ¹⁾		High temperature grease ²⁾	Low temperature grease	Wide temperature range grease	Wide temperature range and silent running grease
Bearing outside diameter	≤ 62 mm	> 62 mm	All	All	All	All
SKF grease code	MT47	MT33	GXN	LT20	GWB	LHT23
Suffix in bearing designation	–	–	HT	LT	WT	LHT23
Consistency class (according to NLGI)	2	3	2	2	2-3	2
Thickener	Lithium soap		Polyurea soap	Lithium soap	Polyurea soap	Lithium soap
Base oil	Mineral oil		Mineral oil	Diester oil	Ester oil	Ester oil
Temperature range, °C³⁾	–30 to +110	–30 to +120	–40 to +150	–55 to +110	–40 to +160	–50 to +140

¹⁾ Except for deep groove ball bearings in the 618 and 619 series with an outside diameter up to 30 mm
²⁾ US standard may differ, based on GJN grease
³⁾ For safe operating temperatures, see the SKF General Catalogue, section "Lubrication – Temperature range – the SKF traffic light concept"



SKF, ICOS and INSOCOAT are registered trademarks of the SKF Group.
SKF Explorer is a trademark of the SKF Group.

© SKF Group 2006

The contents of this publication are the copyright of the publisher and may not be reproduced (even extracts) unless permission is granted. Every care has been taken to ensure the accuracy of the information contained in this publication but no liability can be accepted for any loss or damage whether direct, indirect or consequential arising out of the use of the information contained herein.

Publication **6270 EN** · June 2006

Printed in Sweden on environmentally friendly paper.

www.skf.com